

# Sew & Go Sewing Table

## Adjustable Height – Foldable

### Instructions

Many thanks for your purchase!  
Please find the instructions for setting up your  
Sew & Go Table.

#### Step #1: Basic Set Up (Figure 1)

- Remove board “H”. (Figure 1A)
- Carefully cut the strap tie used to hold the leg assembly during shipping. (Figure 1B)
- Using a Phillips screwdriver and the screws provided, attach the two wheel sets into the pre-drilled holes on part “F”. (Figure 1C)

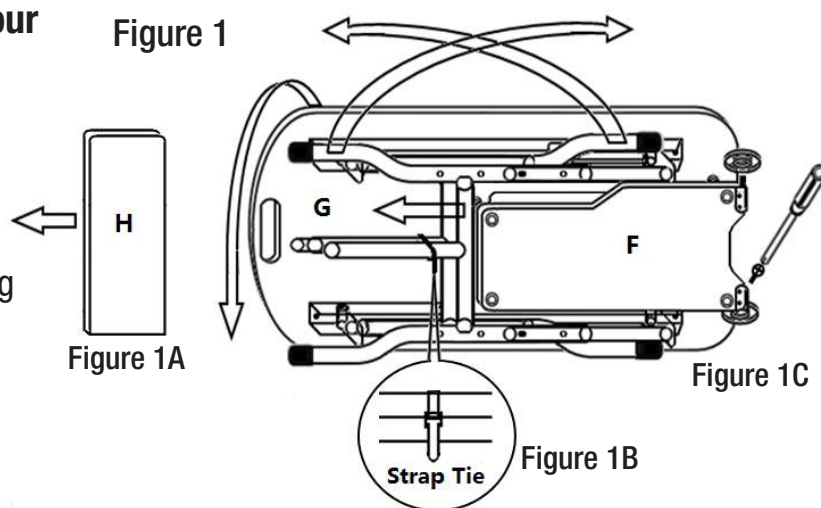

#### Step #2: Leg Height Adjustment if Used at Seated Height (Figure 2)

- Press in the push pin (Figure 2A) and insert part “E” leg assembly into part “D”. (Figure 2A) Repeat on each side.
- Center Tensioning Tube.
- Once the height is selected then take part “A” and insert into part “B”. Once inserted use the push-pin to lock part “A” into part “B”. (Figure 2B) Always extend to the maximum allowable hole. **THIS ADJUSTMENT WILL VARY DEPENDING ON THE HEIGHT OF THE TABLE.**

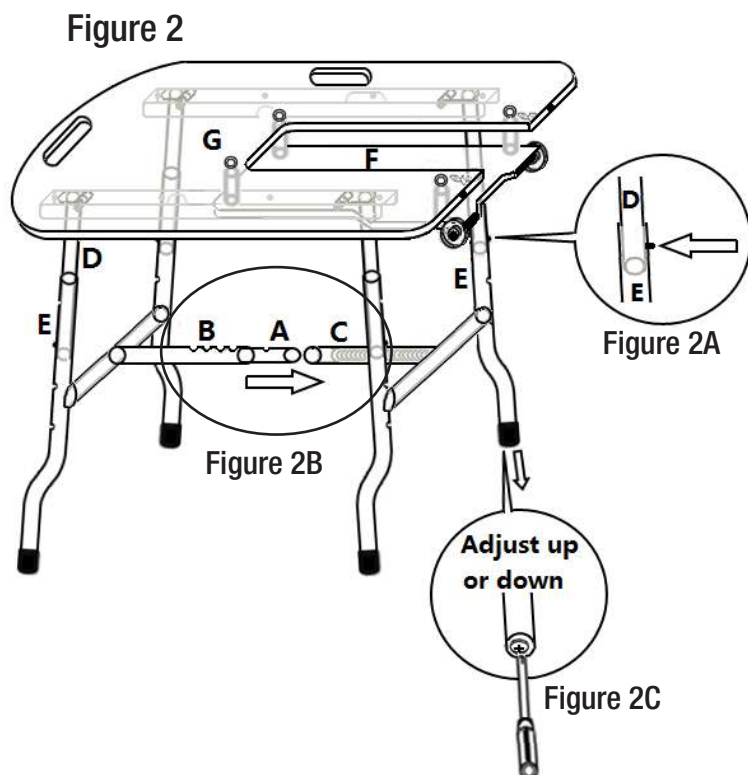

#### Step #3: Individual Fine Leg Adjustment (Figure 2C)

- Remove the foot cover. Using a screwdriver raise or lower according to floor conditions.

#### Step #4: Adjusting Machine Bed (Figure 3)

- The height of the machine bed can be adjusted by tightening or loosening the adjustment with the Allen screws on the top of part "G". (Figure 3A)
- At the inside corners of machine bed there are 6 steel brackets under the tabletop part "G". Pull these brackets to hold the insert part "H". (Figure 3B)

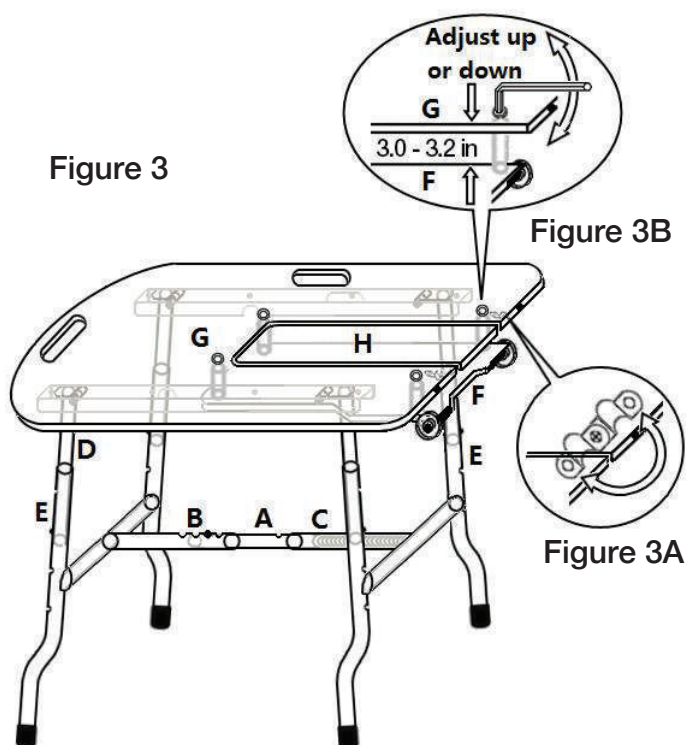

If you have any questions you can contact our  
helpline via email  
[sullivans@sullivansusa.net](mailto:sullivans@sullivansusa.net)  
or  
toll free 800-862-8586.

#### Safety:

This table is not a toy – do not let children play on, under or around it. Do not place more than 30 pounds on the table. Never rest a hot iron directly on the surface.

#### Cleaning:

Using a sponge or soft cloth with mild soap. Do not use any abrasive cleaners or pads.

Sullivans USA  
4341 Middaugh Ave  
Downers Grove, IL 60515

M.T. Sullivans & Co. Pty.Ltd.  
40 Parramatta Road Underwood, Brisbane, Queensland Australia

Sullivans Enterprises (N.Z) Ltd.  
28 Sir William Ave.  
East Tamaki, Auckland New Zealand

Sullivans USA Inc. will replace any missing or defective parts within 30 days of purchase. Fax or email a dated receipt to 630-435-1532, along with your request. This policy does not apply to damages due to shipping. For further assistance, please call 800-862-8586. Some restrictions apply. See website for details.

# Sullivans Sew & Go Table Travel Instructions

To keep the Sullivans Sew & Go Table legs secure while traveling, follow these steps.



**1. Flip your table over and locate the center bar.**



**2. Release the table legs using the push pins and rotate the center bar to slide it between your table surface and Part F, the machine bed.**



**3. Your Sullivans Sew & Go Table is ready for travel.**

If you have any questions, you can contact us at  
[Sullivans@SullivansUSA.net](mailto:Sullivans@SullivansUSA.net)  
or  
toll free 800-862-8586.



# DO NOT RETURN TO THE STORE

**FOR ASSISTANCE WITH MISSING OR REPLACEMENT  
PARTS, INSTALLATION, OR INFORMATION**



[www.sullivansusa.net](http://www.sullivansusa.net)

PLEASE CALL US AT  
**800.862.8586**



[www.sullivansusa.net](http://www.sullivansusa.net)

Sullivans USA, Inc. will replace any missing or defective parts within 30 days of purchase. Fax a dated receipt with your contact information, the lot number on your instructions, and your request to **630-435-1532** or e-mail to **Sullivans@SullivansUSA.net**. To expedite this process, include any parts you may need in your request. This policy does not apply to damages due to shipping. For further assistance, please call 800-862-8586.

Please note that the no-charge Replacement Policy does not apply to items sold as is, clearance, closeout, final sale, etc. Any parts requested under these circumstances will be charged to the customer, including shipping charges. Shipping charges for replacement parts to Alaska, Hawaii or any point outside of the Contiguous United States are not covered under our policy. Some restrictions apply. See website for details. If you are outside of the 30 day period, replacement parts are available for purchase.

**4341 MIDDAUGH AVENUE • DOWNERS GROVE, IL 60515 • ORDERS: 800.862.8586 • FAX: 630.435.1532**