

SULLIVANS

Item No.

**Deluxe Cutting Table**

**Instructions**

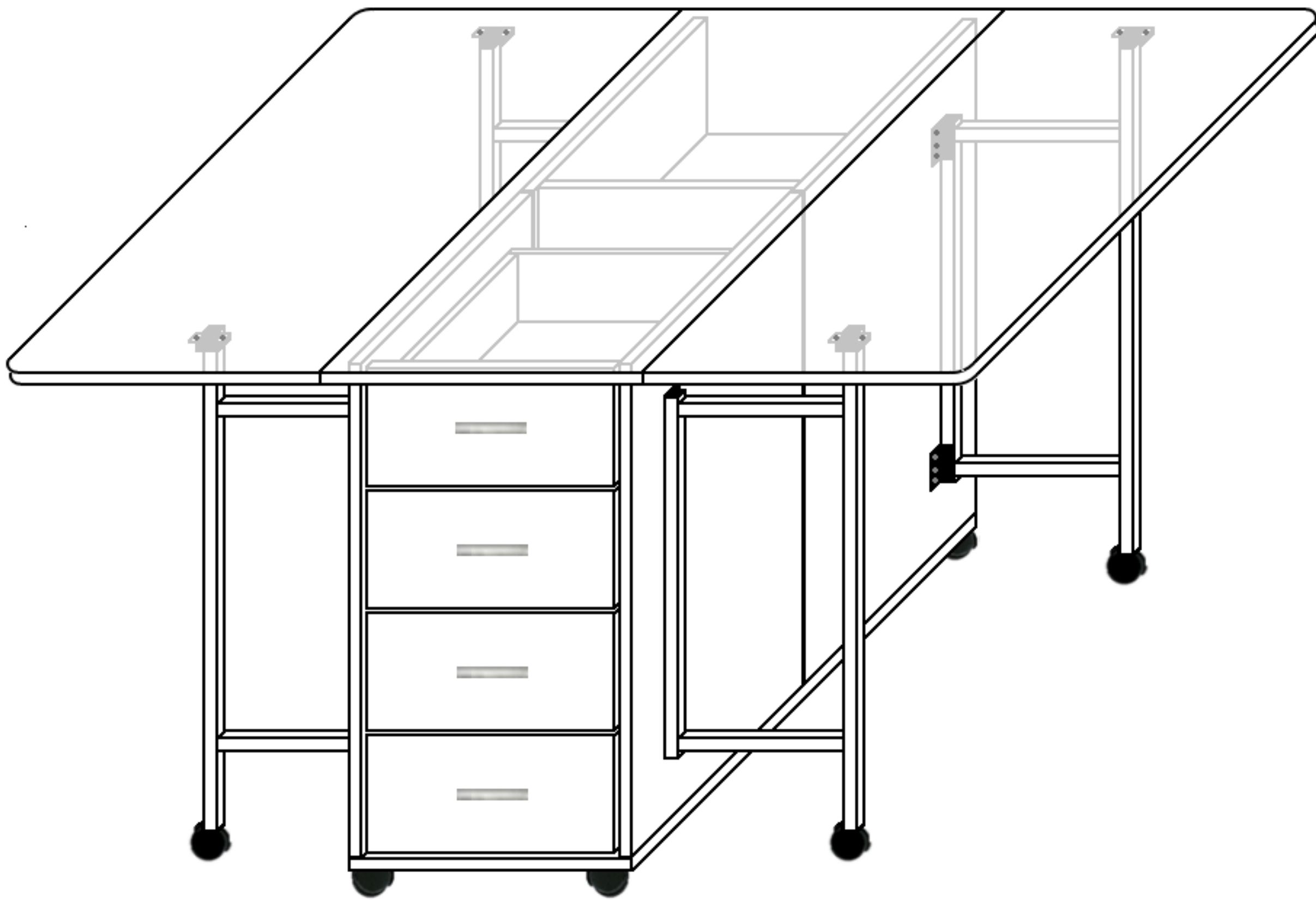

***[www.sullivans.net/usa](http://www.sullivans.net/usa)***











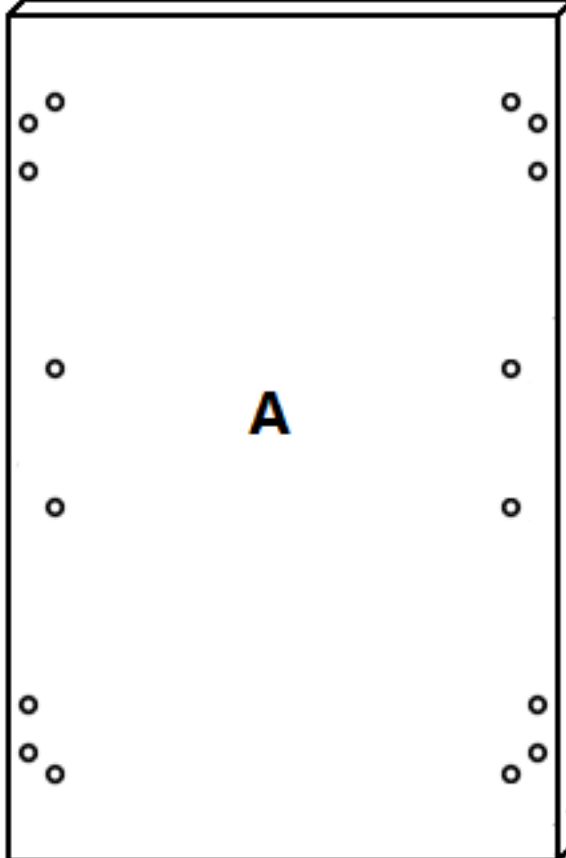
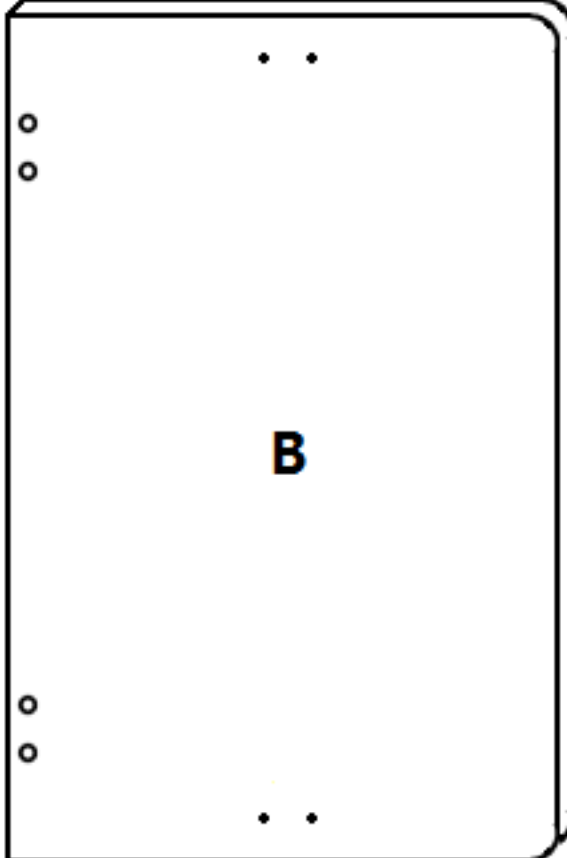
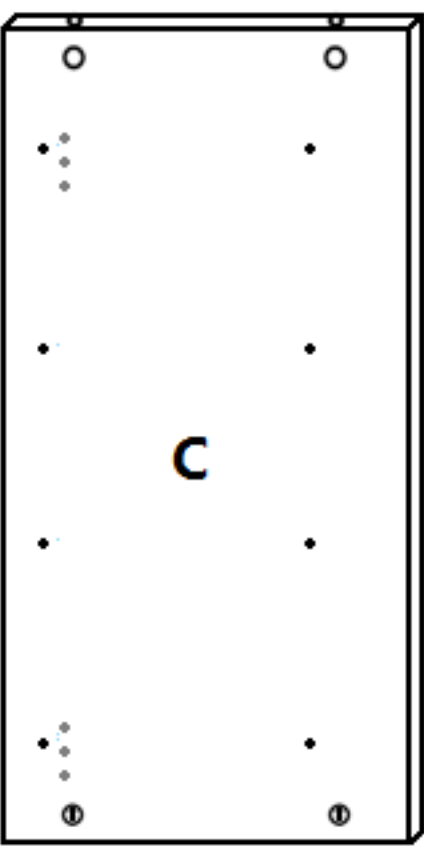
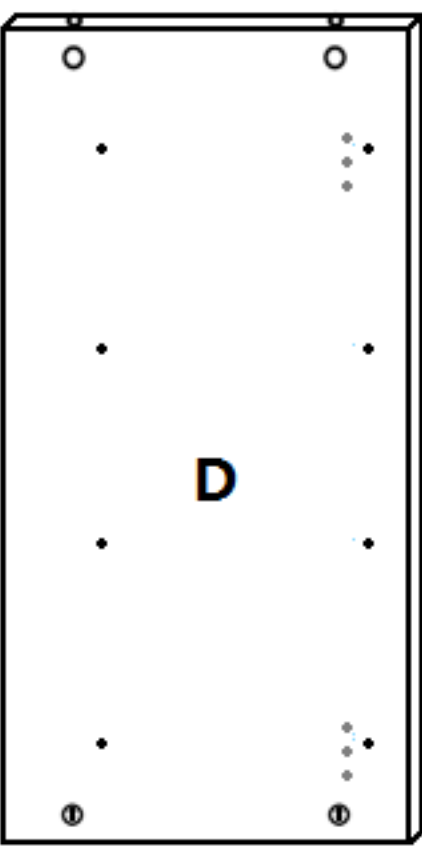
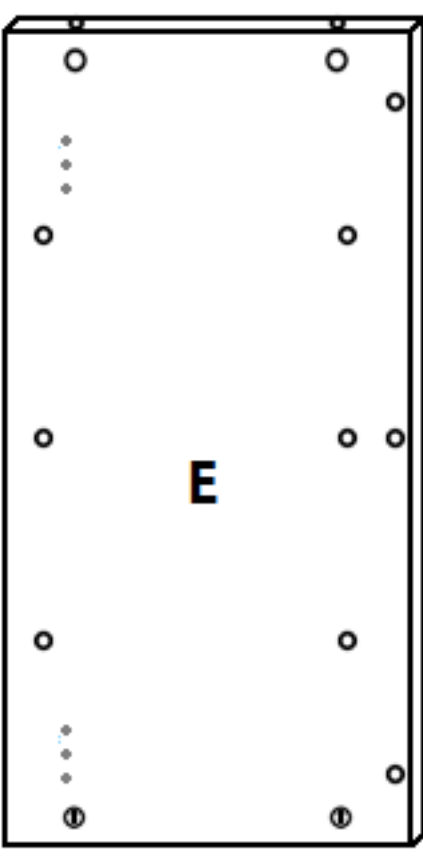
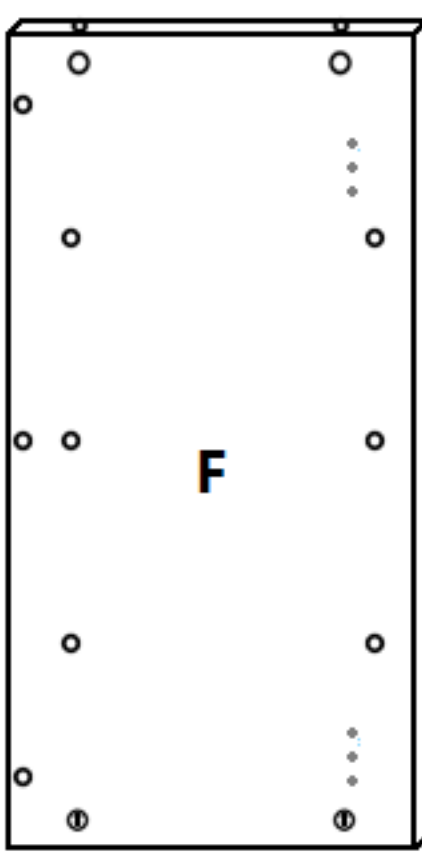
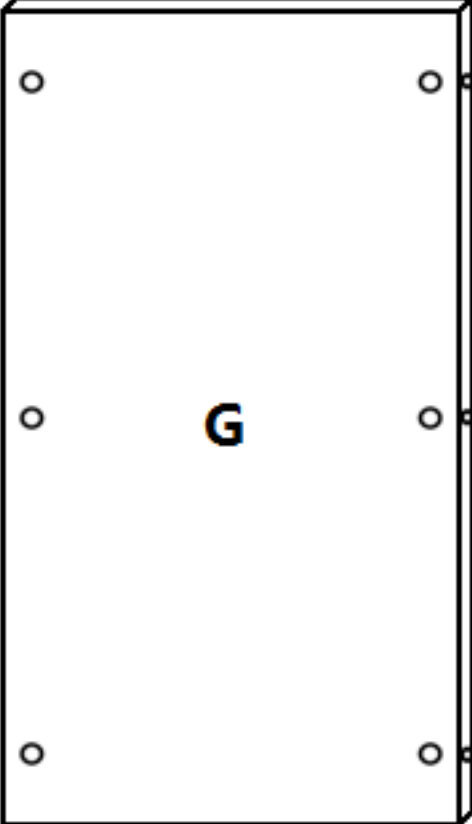
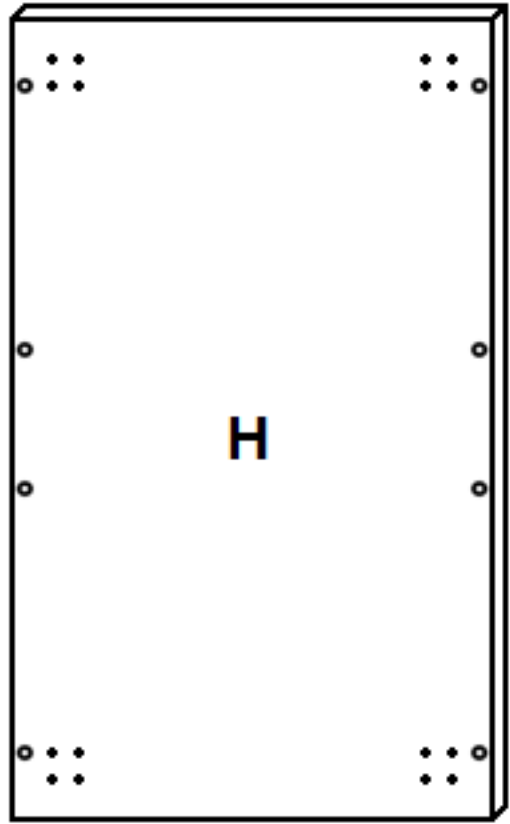
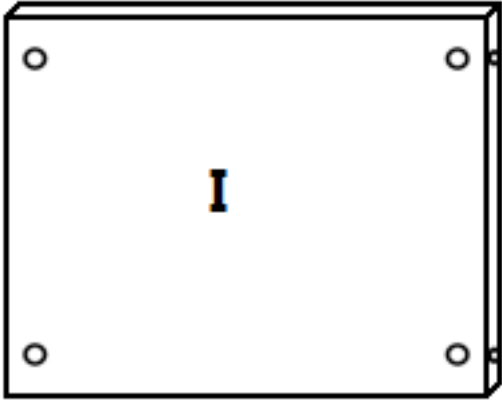
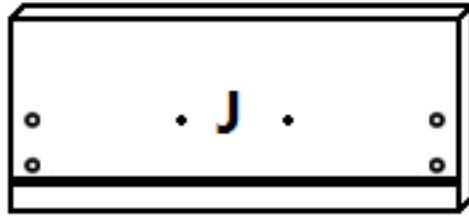
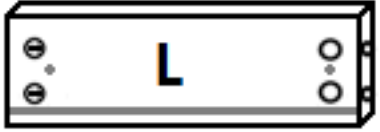
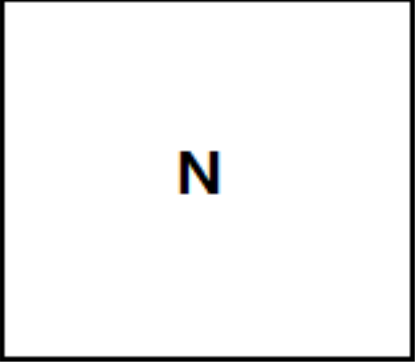
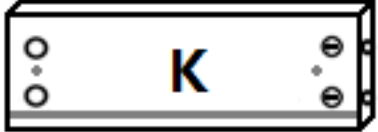
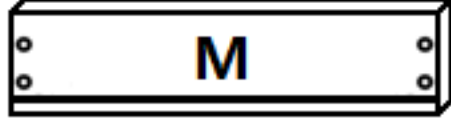

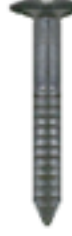

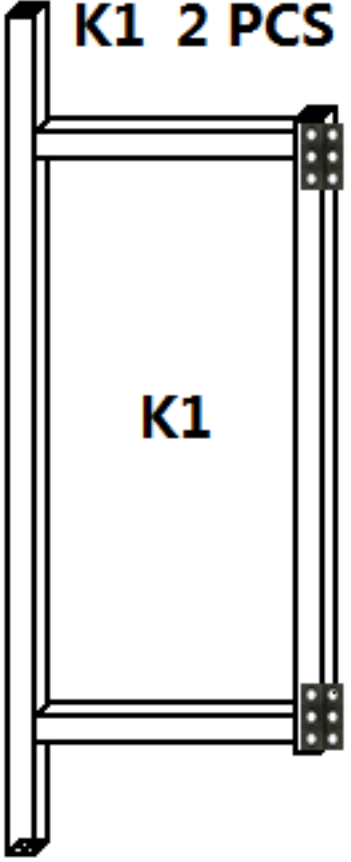
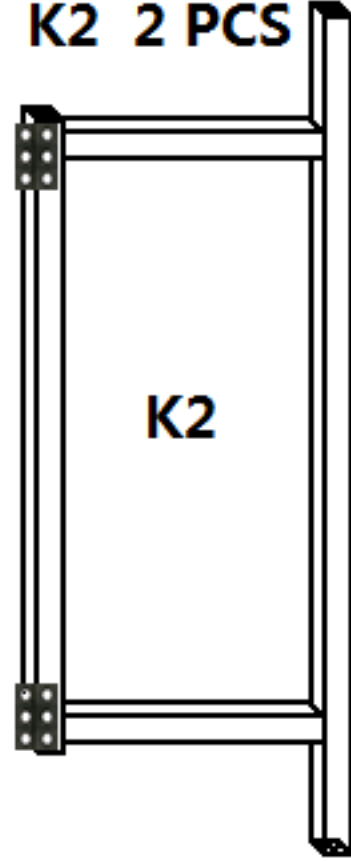

**Tools needed:**

**Phillips Head screwdriver.**

**Assembly Time:**

**App. 80 minutes**



<p><b>A 1PC</b></p>  <p><b>A</b></p> <p><b>Table Top</b></p>		<p><b>B 2PCS</b></p>  <p><b>B</b></p> <p><b>Table Top</b></p>		<p><b>C 1PC</b></p>  <p><b>C</b></p> <p><b>Left Side Panel</b></p>		<p><b>D 1PC</b></p>  <p><b>D</b></p> <p><b>Right Side Panel</b></p>		<p><b>E 1PC</b></p>  <p><b>E</b></p> <p><b>Left Side Panel</b></p>		<p><b>F 1PC</b></p>  <p><b>F</b></p> <p><b>Right Side Panel</b></p>	
<p><b>G 1PC</b></p>  <p><b>G</b></p> <p><b>Back Panel</b></p>		<p><b>H 1PC</b></p>  <p><b>H</b></p> <p><b>Bottom Panel</b></p>		<p><b>I 3PCS</b></p>  <p><b>I</b></p> <p><b>Partition Panel</b></p>		<p><b>J 4PCS</b></p>  <p><b>J</b></p> <p><b>Front Panel For Drawer</b></p>		<p><b>L 4PCS</b></p>  <p><b>L</b></p> <p><b>Right Side Drawer Panel</b></p>		<p><b>N 4PS</b></p>  <p><b>N</b></p> <p><b>Bottom Board For Drawer</b></p>	
<p><b>K 4PCS</b></p>  <p><b>K</b></p> <p><b>Left Side Drawer Panel</b></p>		<p><b>M 4PS</b></p>  <p><b>M</b></p> <p><b>Back Panel For Drawer</b></p>		<p>① 56 PCS   ② 16 PCS   ③ 24 PCS   ④ 16 PCS   ⑤ 8 PCS   ⑥ 4 PCS   ⑦ 4 PCS</p>        <p><b>3.5*12 Screws</b>   <b>3.5*14 Screws</b>   <b>5*50 Screws</b>   <b>6*10 Screws</b>   <b>3*12 Screws</b>   <b>Magnet</b>   <b>Hinges</b></p>							
<p><b>K1 2 PCS</b></p>  <p><b>K1</b></p> <p><b>Support Panel</b></p>		<p><b>K2 2 PCS</b></p>  <p><b>K2</b></p> <p><b>Support Panel</b></p>		<p>⑧ 4 PCS   ⑨ 4 PCS   ⑩ 42 PCS   ⑪ 42 PCS   ⑫ 8 PCS   ⑬ 4 PCS   ⑭ 8 PCS   ⑮ 1 PS   ⑯ 1 PS</p>          <p><b>Caster</b>   <b>Caster</b>   <b>Cam-bolt</b>   <b>Cam-lock</b>   <b>Screws</b>   <b>Handle</b>   <b>Slider</b>   <b>Allen Key</b>   <b>Allen Key</b></p>							

Step 1A, Use part #4 Screws to screw the part

#7 Hinges onto table top A & B.

Step 1B, Screw the part #10 Cam-bolt into

Table Top A & B.

Step 1C, Use part #5 Screws to screw the part

#6 Magnet onto Table Top B.

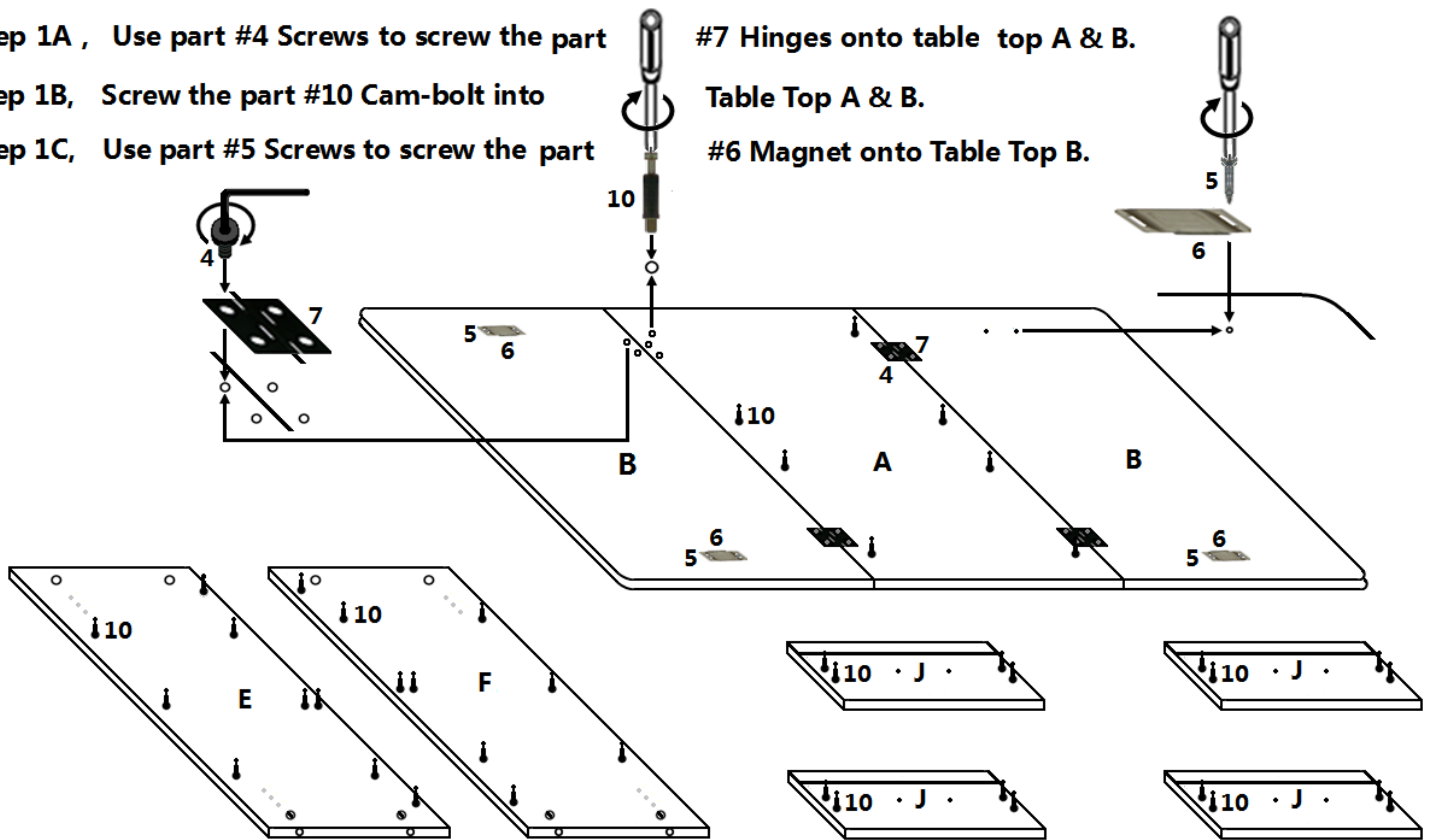

Step 2A, Rotate the part #11 Cam-locks left and right and press them into panel C, D, E, F, G, I, K and L.

Step 2B, Press the locking block of the part #14 Slider, pull out the inner Slider, use part #1 Screws to screw the outer sliders onto the panel C & D, and use part #1 Screws to screw the inner sliders onto the panel K & L.

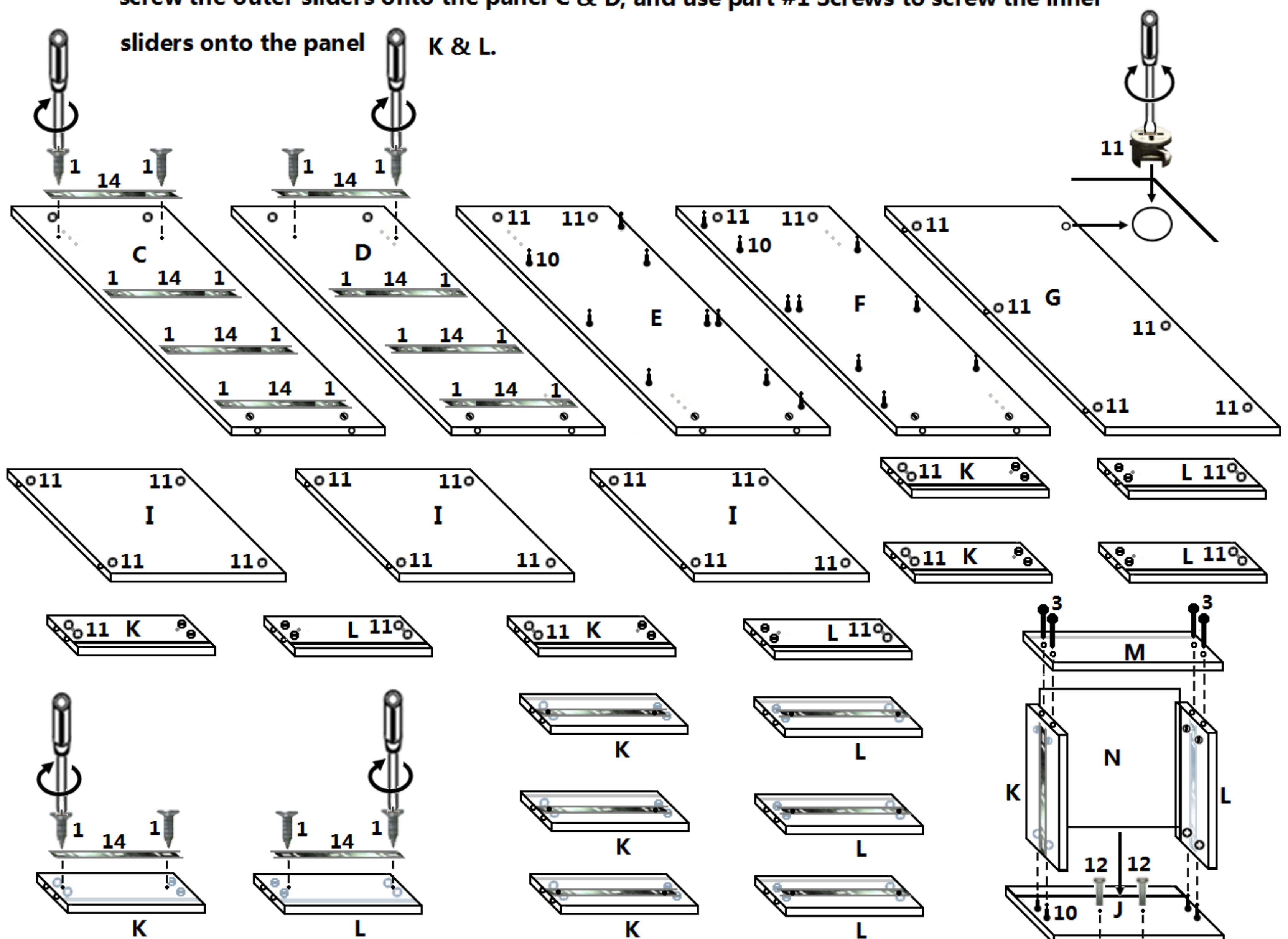

Step 3, Insert the part #11 Cam-locks on Panel K & L into the part #10 Cam-bolts on the Panel J, insert panel N into the slots of panel K, L and J, and tighten these Cam-locks clockwise. Use part #3 Screws to screw the panel M with panel K & L, use part #12 Screw to screw the part #13 onto panel J.

**Step 4A,** Insert the part #11 Cam-locks on Panel G & I into the part #10 Cam-bolts on the panel F, Insert the part #10 Cam-bolts on Panel E into the part #11 Cam-locks on the Panel G & I, and tighten these Cam-locks clockwise.

**Step 4B,** Insert the part #11 Cam-locks on the Panel C, D, E and F into the part #10 Cam-bolts on the Table Top A, and tighten these Cam-locks clockwise.

**Step 4C ,** Use part #3 Screws to screw the panel H with panel C, D, E and F, use part #2 Screws to screw the part #9 Casters onto the panel H.

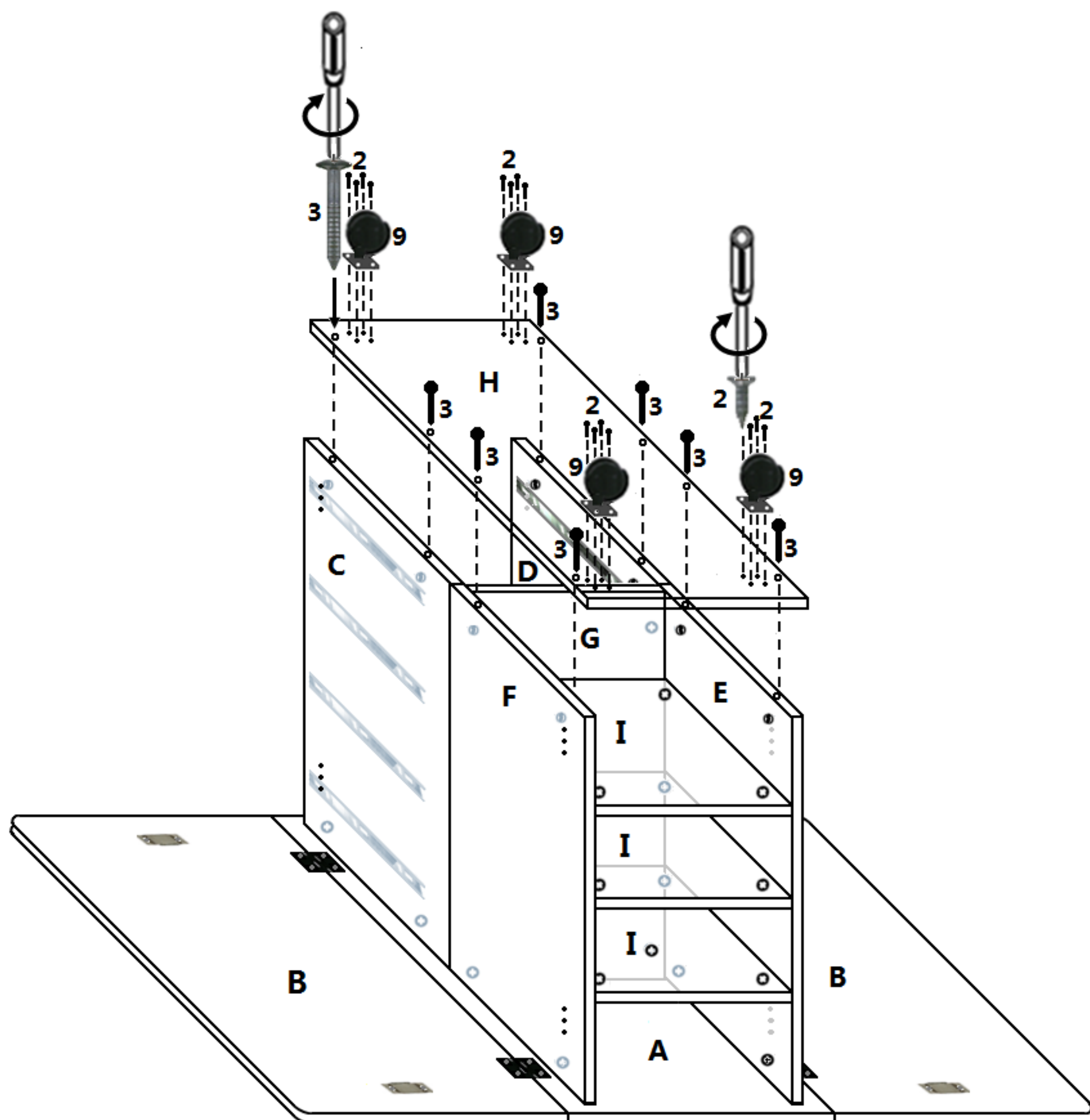
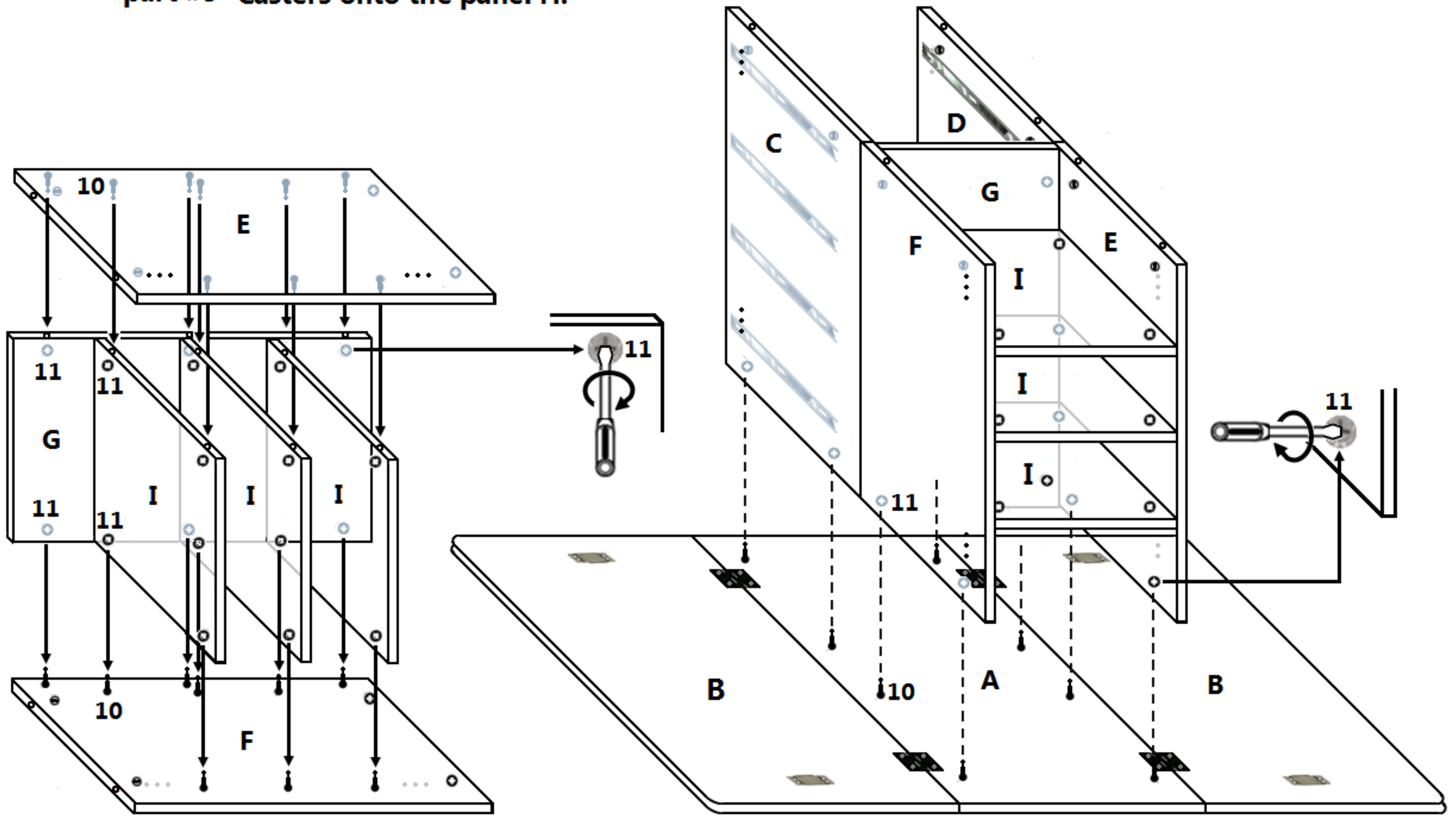

Step 5A, Use part #1 Screws to screw the Support Panel K1 & K2 onto Panel C, F, E and D.

Step 5B, Insert the part #8 Casters onto the Support Panel K1 & K2.

Step 5C, Close the Support Panel K1 & K2, Turn over the table. Insert the drawers into the Sliders. OK.

